

DESPIECE

DISASSEMBLY

Nº	Descripción Description	Cant. Quant.	Material Material
1	ANILLO DE SEGURIDAD SPRING CLIP	2	ACERO (2) STEEL (2)
2	TAPA DOBLE EFECTO DOUBLE ACTING CAP	2	POLIAMIDA + FV POLYAMIDE + FG
3	JUNTA TÓRICA TAPA CAP O-RING	2	N.B.R. N.B.R.
4	ÉMBOLO PISTON	2	POLIARILAMIDA POLYARILAMIDE
5	CILINDRO CYLINDER	1	POLIAMIDA + FV POLYAMIDE + FG
6	ARANDELA WASHER	1	POLIAMIDA 6 POLYAMIDE 6
7	ANILLO SEGURIDAD SPRING CLIP	1	ACERO INOXIDABLE STAINLESS STEEL
8	INDICADOR VISUAL POSITION INDICATOR	1	POLIAMIDA POLYAMIDE
9	GUIA ÉMBOLO PISTON GUIDE	2	POLIACETAL POLYACETAL
10	ANILLO GUIA GUIDE RING	2	POLIACETAL POLYACETAL
11	JUNTA TÓRICA ÉMBOLO PISTON O-RING	2	N.B.R. N.B.R.
12	JUNTA TÓRICA O-RING	2	N.B.R. N.B.R.
13	JUNTA TÓRICA O-RING	2	N.B.R. N.B.R.
14	JUEGO DE MUELLES SPRINGS SET	1	DIN-17223-C (2) (4) DIN-17223-C (2) (4)
15	TAPA SIMPLE EFECTO SPRING RETURN CAP	2	POLIAMIDA + FV POLYAMIDE + FG
16	EJE SHAFT	1	ACERO INOX AISI-303 AISI-303 STAINLESS STEEL
17	PINON GEAR	1	ALEACIÓN ALUMINIO (5) ALUMINIUM ALLOY (5)
18	INSERTOS ROSCADOS THREAD INSERTS	10	ACERO INOX STAINLESS STEEL



**ACTUADOR NEUMÁTICO DE POLIAMIDA
POLYAMIDE PNEUMATIC ACTUATOR**



PP20: DOBLE EFECTO / DOUBLE ACTING
PP20S: SIMPLE EFECTO / SPRING RETURN

- (2) RECUBIERTO POR CATAFORESIS.
COVERED BY CATAPHORESIS.
- (4) CANTIDAD VARIABLE, CONSULTAR TABLAS PARES SIMPLE EFECTO.
VARIABLE QUANTITY, PLEASE SEE THE SPRING RETURN TORQUE CHART.
- (5) BRUÑIDO CON BOLAS
BALL BURNISHING

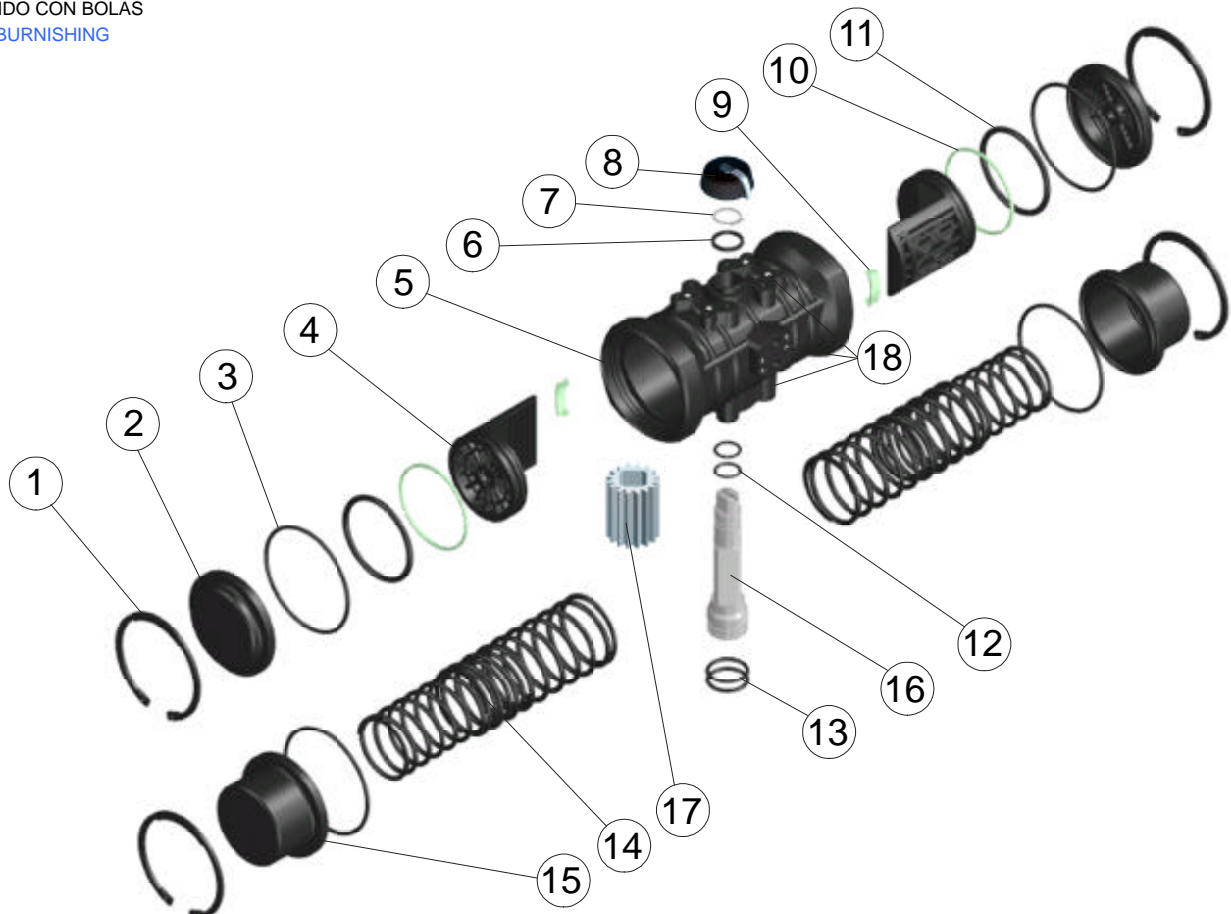

MODELOS MODELS	TIEMPO DE MANIOBRA EN SEG. CYCLE TIME IN SECS.		PESOS WEIGHTS		CAPACIDAD EN LITROS CAPACITY IN LITRES	
	PARA ABRIR TO OPEN	PARA CERRAR TO CLOSE	Kg.	Lb.	PARA ABRIR TO OPEN	PARA CERRAR TO CLOSE
PP20	0,4	0,4	2,94	6,47	0,8	0,7
PP20S	0,5	0,5	4,95	10,9	0,8	

Tiempo de maniobra sin par resistente a 6 bar
Cycle time w/o resistant torque at 6 bar

Dimensiones en mm
Dimensions in mm

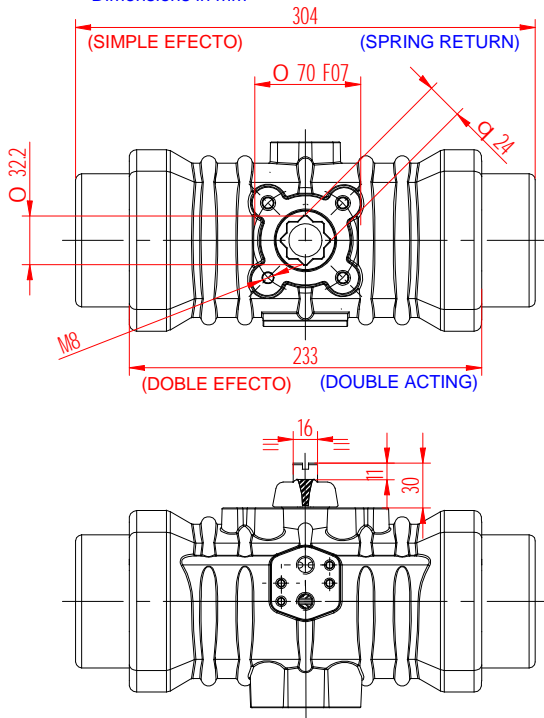

Para calcular el consumo, multiplicar las cifras del cuadro por la presión real de trabajo

To calculate the consumption, multiply the above figures by the real working pressure

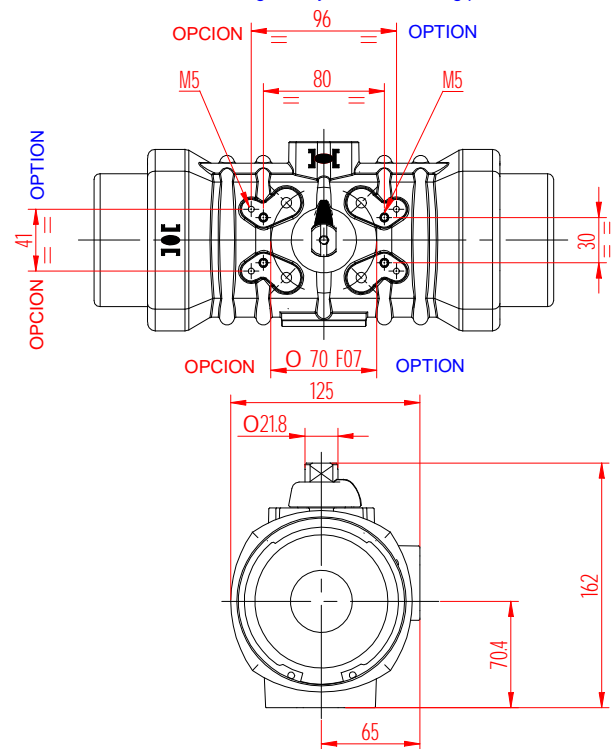

PARES DOBLE EFECTO DOUBLE ACTING TORQUES

PP20	PRESION AIRE AIR PRESSURE						
	bar	3	4	5	6	7	8
p.s.i.	43,7	58,3	72,8	87,4	102	116,5	
Nm	77,7	107	136,3	165,5	194,8	224	
Lb. In	687,8	947,3	1206,2	1465,2	1724,1	1982,8	

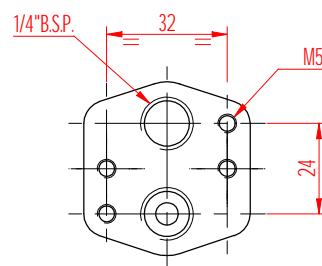

NORMA NAMUR E.V
SOLENOID NAMUR NORM

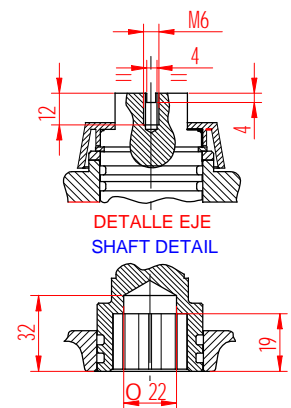

PARES SIMPLE EFECTO SPRING RETURN TORQUES

PP20S	PAR MUELLES SPRING TORQUES		PAR AIRE A LA PRESION INDICADA AIR TORQUE AT INDICATED PRESSURE														
			3		4		5		6		7		8		bar		
	INICIAL INITIAL	FINAL END	INICIAL INITIAL	FINAL END	INICIAL INITIAL	FINAL END	INICIAL INITIAL	FINAL END	INICIAL INITIAL	FINAL END	INICIAL INITIAL	FINAL END	INICIAL INITIAL	FINAL END	INICIAL INITIAL	FINAL END	p.s.i.
N																	
4*	103,3	64,2					72,1	33	101,3	62,2	130,6	91,5	159,8	120,7			Nm
	915	568,5					637,6	291,6	896,7	550,6	1155,5	809,5	1414,2	1068,2			Lb. in
3	92,2	55,9			51,2	14,9	80,4	44,1	109,6	73,3	139	102,6	168,2	131,9			Nm
	815,7	494,4			452,9	131,6	711,8	390,5	970,8	649,5	1229,7	908,4	1488,4	1167			Lb. in
2	67	39,1	38,6	10,7	67,9	40	97,2	69,3	126,4	98,5	155,7	127,8					Nm
	593,2	346	341,8	94,6	601,3	354,1	860,1	613	1119,2	872	1378	1130,9					Lb. in
1	41,9	25,1	52,6	35,8	81,9	65,2	111,2	94,4	140,4	123,6							Nm
	370,7	222,5	465,3	317,1	724,8	576,6	983,7	835,4	1242,7	1094,5							Lb. in

N: Número de muelles por banda
Number of springs per side

* Número de muelles estándar
* Standard number of springs