

Pressure switch MDR 1



Pressure switch MDR 1 / 6, Pump version

Single phase
 Switching capacity 4.0 kW
 Max. cut-out pressure 6 bar
 Incl. cable glands PG 11 Z/ZK
 2-pole (N.C.) Steel flange
 Acc. to EN 60947
 Optional differential adjustment



Steel flange ST-Ü

Type overview MDR 1 / 6 bar

Order reference	ON / OFF Rotary knob	Pressure range P _{OFF} in bar	Flange	Weight in g	Part No.
MDR-1 DSD BAEA 017A030 XDE XXX	-	2.5 - 6	G 1/4" ST	220	212119
MDR-1 DTD BAEA 017A030 XDE XXX	-	2.5 - 6	G 1/4" ST-Ü	220	212126

Cable glands for retrofitting see Accessories!



MDR 1/11.. +EA

Pressure switch MDR 1 / 11, Compressor version

Single phase
 Switching capacity 4.0 kW
 Max, cut-out pressure 11 bar
 Incl. cable glands PG 11 Z/ZK and unloader valve AEV 1 S
 2-pole (N.C.)
 Acc. to EN 60947
 Optional differential adjustment

Type overview MDR 1 / 11 bar

Order reference	ON / OFF Rotary knob	Pressure range P _{OFF} in bar	Flange	Weight in g	Part No.
MDR-1 GBA AAEA 060A080 QDE XXX	EA	2.5 - 11	G 1/4"	220	212133
MDR-1 GEA AAEA 060A080 QDE XXX	EA	2.5 - 11	F4 1/4"	220	212140
MDR-1 GFA AAEA 060A080 QDE XXX	EA	2.5 - 11	F4 3/8"	220	212157
MDR-1 GBA BAEA 060A080 QDE XXX	-	2.5 - 11	G 1/4"	220	216049
MDR-1 GEA BAEA 060A080 QDE XXX	-	2.5 - 11	F4 1/4 "	220	216025
MDR-1 GFA BAEA 060A080 QDE XXX	-	2.5 - 11	F4 3/8"	220	216063

Unloader valves and cable glands for retrofitting see Accessories!

Technical Data MDR 1

Technical Data MDR 1 acc. to EN 60947	
Rated insulation voltage U _i	500 V
Motor switching capacity (AC 3) U _e =240 V (1-)	4.0 kW
Electrical life (AC 3) Cycles	> 1 x 10 ⁵
Mechanical life Cycles	> 5 x 10 ⁵
Max. electrical cycles Cycles/h	120
Max. mechanical cycles Cycles/h	600
Rated operational current I _e at 240 V AC	20 A
Bursting strength P _z	> 35 bar

Technical Data MDR 1 acc. to EN 60947	
Permissible media temperature Air	- 5...+ 80 °C
Permissible media temperature Water	+ 70 °C
Degree of Protection acc. to EN 60529	IP 44
Conductor cross-section 1 .. fine stranded cable 1 x / 2 x	2.5 / 2.5mm ²
Conductor cross-section 1 rigid cable 1 x / 2 x	2.5 / 2.5mm ²

Diaphragm media resistance MDR 1	
Acetylene, Butane, Ethylene glycol, Carbon dioxide, Air, Mineral oils, Water, Distilled water, Sea water, Hydrogen, Water steam	resistant

A detailed overview of diaphragm media resistance for all pressure switches can be found in the table on page 2.11

Pressure switch MDR 1



Dimensions / Circuit Diagrams MDR 1

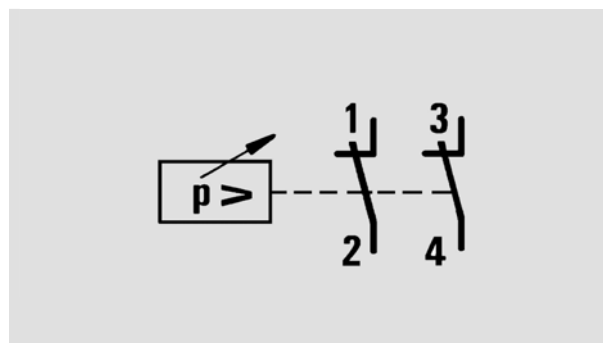
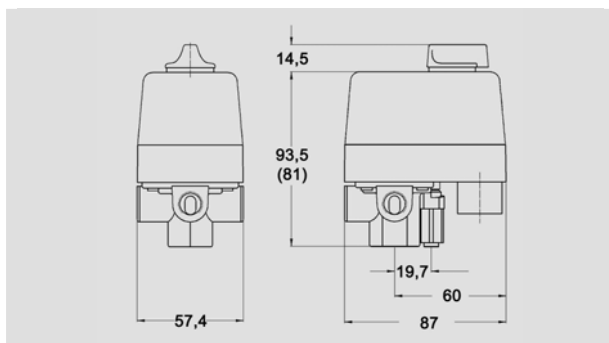

Pressure switch **MDR-1**

Accessories MDR 1

Order reference	Description	Weight in g	Part No
EV 1S	Unloader valves with quick-connect 6 mm for plastic unloader valves	25	226765
AEV 1S	Delayed unloader valves with quick-connect 6 mm for plastic unloader valves	25	217541
WN	Cable glands Grommet	6	200888
PG 11 G	Conduits for mounting of cable glands (Inner thread)	6	255024
PG 11 Z	With strain relief	12	255031
PG 11 ZK	With strain relief and cable support	12	255048
H1 (Cover MDR 1)	Cover Cover without On/Off lever (Neutral version, without marking)	40	230700
H1-EA (Cover MDR 1+EA)	Cover with On/Off lever for manual On/Off (Neutral version, without marking)	40	227366
Cover MDR 1 + EA + lever	Conversion kit H1 to cover H1-EA	40	230717
MDR-1 Differential kit	Differential adjustment Kit for setting cut-in and differential pressures (10 pcs.)	20	230618

Unloader valves / Delayed unloader valves



EV 1S



AEV 1S

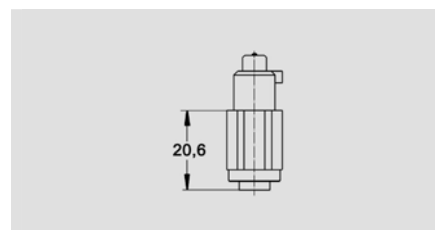

EV 1S / AEV 1S

Pressure switch MDR 1



Cable glands MDR 1



Grommet



PG 11 G



PG 11 Z



PG 11 ZK

Pressure Diagrams MDR 1

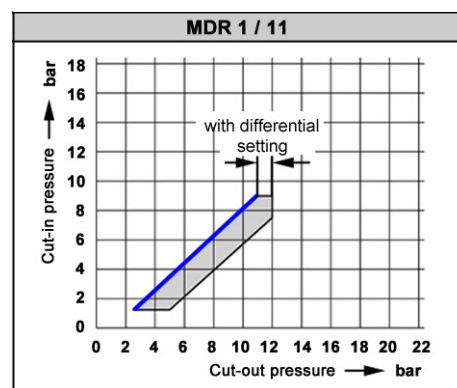
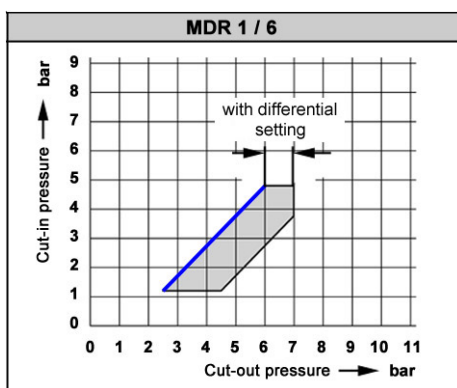

Explanation

Devices without differential pressure adjustment

After selecting the cut-in pressure, the cut-out pressure can be read from the pressure diagram. If only the cut-out pressure is known, the cut-in pressure to be set can also be determined from the diagram.

Example: MDR 1/6 without differential pressure adjustment

For a preselected cut-in pressure of 4 bar, the cut-out pressure is 5 bar. If, for example, the cut-out pressure is to be 4 bar, a cut-in pressure of approx. 2.7 bar has to be set.

Devices with differential pressure adjustment

An intersecting point is determined in the diagram by selecting a pair of cut-in and cut-out pressure values. If this point lies within the shaded area, this pair of values can be set on the pressure switch. If this point lies outside the shaded area, these values cannot be set.

Example: MDR 1/11 with differential pressure adjustment

With a preselected cut-in pressure of 4 bar, the cut-out pressure can be determined and set between 5.4 and 8 bar using the differential pressure adjustment