

DESPIECE

DISASSEMBLY



Nº	Descripción Description	Cant. Quant.	Material Material
1	TORNILLO ALLEN TAPA CAP ALLEN SCREW	8	ACERO INOXIDABLE AISI-304 AISI-304 STAINLESS STEEL
2	TAPA CAP	2	ALEACIÓN ALUMINIO (2) + (7) ALUMINIUM ALLOY (2) + (7)
3	JUNTA TÓRICA TAPA CAP-O-RING	2	N.B.R. N.B.R.
4	ÉMBOLO PISTON	2	ALEACIÓN ALUMINIO (2) ALUMINIUM ALLOY (2)
5	CILINDRO CYLINDER	1	ALEACIÓN DE ALUMINIO (2) + (1) ALUMINIUM ALLOY (2) + (1)
6	ARANDELA WASHER	1	POLIACETAL POLYACETAL
7	ANILLO DE SEGURIDAD SPRING CLIP	1	ACERO INOXIDABLE STAINLESS STEEL
8	INDICADOR VISUAL POSITION INDICATOR	1	POLIAMIDA POLYAMIDE
9	GUÍA ÉMBOLO PISTON GUIDE	2	POLIACETAL POLYACETAL
10	ANILLO GUÍA GUIDE RING	2	POLIACETAL + Mb POLYACETAL + Mb
11	JUNTA TÓRICA ÉMBOLO PISTON O-RING	2	N.B.R. N.B.R.
12	JUNTA TÓRICA EJE SHAFT O-RING	2	N.B.R. N.B.R.
13	JUNTA TÓRICA EJE SHAFT O-RING	2	N.B.R. N.B.R.
14	MUELLES PRECARGADOS PRELOADED SPRINGS	12	DIN-17223-C (6) (4) DIN-17223-C (4) (4)
15	LEVA CAM	1	ACERO (2) STEEL (2)
16	EJE SHAFT	1	ACERO (2) STEEL (2)
17	JUNTA TÓRICA PLACA PLATE O-RING	2	N.B.R. N.B.R.
18	ARANDELA TAPA CAP WASHER	8	ACERO INOXIDABLE AISI-304 AISI-304 STAINLESS STEEL
19	TUERCA NUT	4	ACERO INOXIDABLE AISI-304 AISI-304 STAINLESS STEEL
20	PLACA CONEXIÓN NEUMÁTICA PNEUMATIC CONNECTION PLATE	1	POLIAMIDA + FV POLYAMIDE + FG
21	TORNILLO ALLEN PLACA PLATE ALLEN SCREW	2	ACERO INOXIDABLE AISI-304 AISI-304 STAINLESS STEEL
22	TORNILLO HEXAGONAL HEXAGONAL SCREW	2	ACERO STEEL
23	TUERCA NUT	2	ACERO INOXIDABLE AISI-304 AISI-304 STAINLESS STEEL
24	ARANDELA BUSHING	2	ACERO INOXIDABLE AISI-316 AISI-316 STAINLESS STEEL
25	JUNTA TÓRICA O-RING	2	N.B.R. N.B.R.
26	CREMALLERA SPUR RACK	1	ACERO (8) STEEL (8)

ACTUADOR NEUMÁTICO DE ALUMINIO
(GIRO: 180°)
ALUMINIUM PNEUMATIC ACTUATOR
(ROTATION: 180°)



PAG10: Doble Efecto / Double Acting
PAG10S: Simple Efecto / Spring Return

- (1) RECUBRIMIENTO CON POLIAMIDA.
COVERED WITH POLYAMIDE.
- (2) RECUBRIMIENTO POR CATAFORESIS.
COVERED BY CATAPHORESIS.
- (3) RECUBIERTO CON NÍQUEL-TEFLON.
COVERED BY NIKEL-P.T.F.E.
- (4) CANTIDAD VARIABLE, CONSULTAR
TABLAS PARES SIMPLE EFECTO.
VARIABLE QUANTITY, PLEASE SEE THE
SPRING RETURN TORQUE CHART.
- (5) BRUÑIDO CON BOLAS.
BALL BURNISHING.
- (6) PASIVADO DE CROMO TRIVALENTE.
TRIVALENT CHROMINIUM PASSIVATION.
- (7) RECUBRIMIENTO CON POLIURETANO.
COVERED WITH POLYURETHANE.
- (8) ZINCADO.
ZINC COATED.

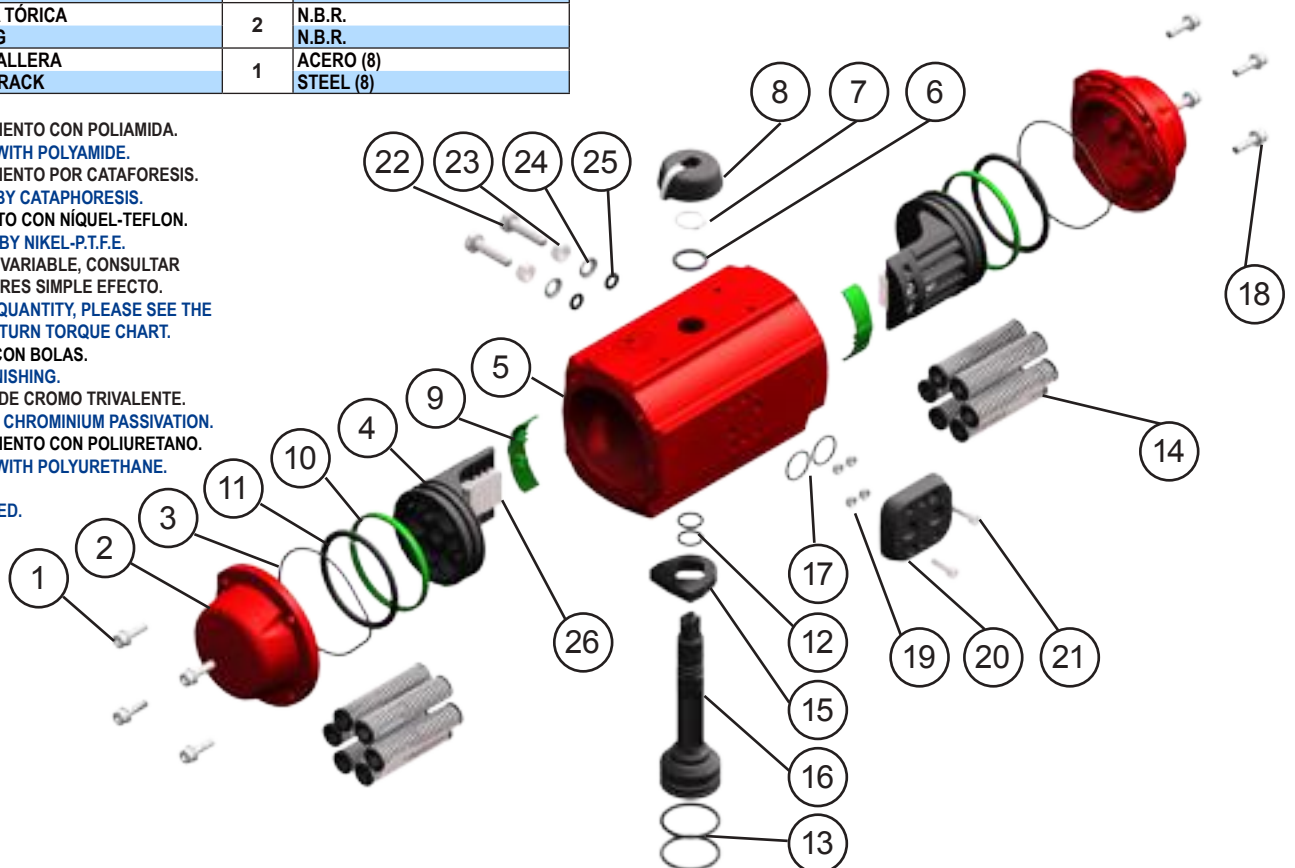

MODELOS MODELS	TIEMPO DE MANIOBRA EN SEG. CYCLE TIME IN SECS.		PESOS WEIGHTS		CAPACIDAD EN LITROS CAPACITY IN LITRES	
	PARA ABRIR TO OPEN	PARA CERRAR TO CLOSE	Kg.	Lb.	PARA ABRIR TO OPEN	PARA CERRAR TO CLOSE
PAG10	0,25	0,25	3,1	6,82	0,35	0,45
PAG10S	0,3	0,3	3,5	7,7	0,35	

Tiempo de maniobra sin par resistente a 6 bar.
Cycle time w/o resistant torque at 6 bar.

Dimensiones en mm.
Dimensions in mm.

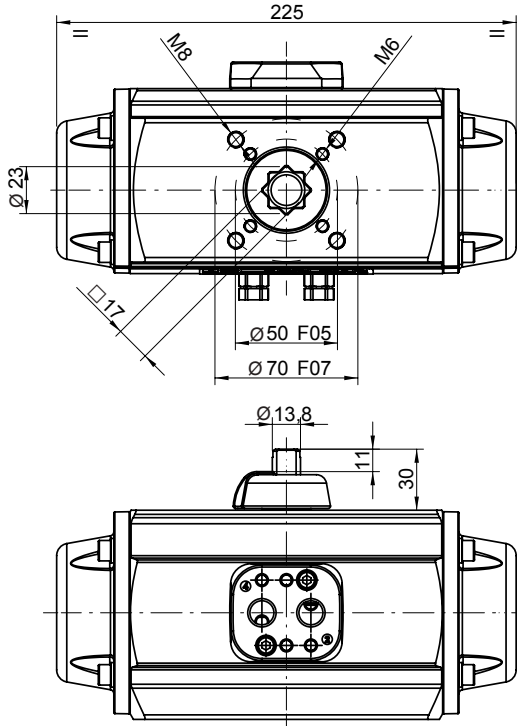

Para calcular el consumo, multiplicar las cifras del cuadro por la presión real de trabajo.

To calculate the consumption, multiply the above figures by the real working pressure.

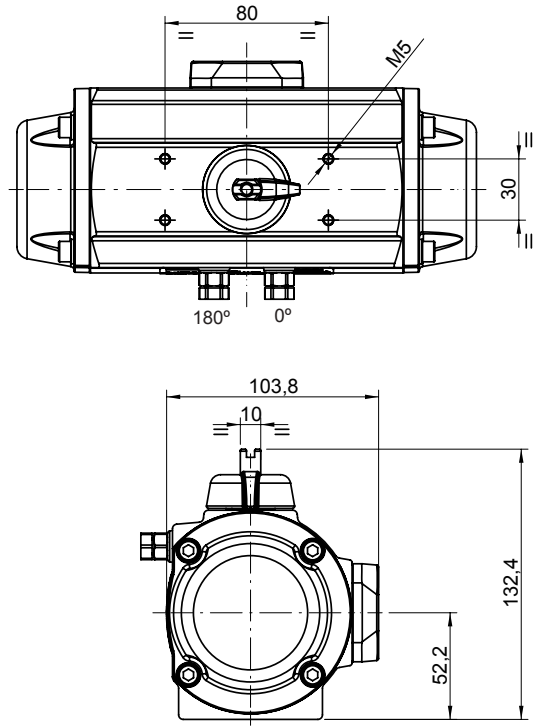

PARES DOBLE EFECTO DOUBLE ACTING TORQUES

PAG10	PRESION AIRE AIR PRESSURE						
bar	3	4	5	5,5	6	7	8
p.s.i	43,5	58	72,5	79,8	87	101,5	116
Nm	16,5	22,8	29,2	33	36	41,9	48,2
Lb.in	146	202	258	288	314	370	427

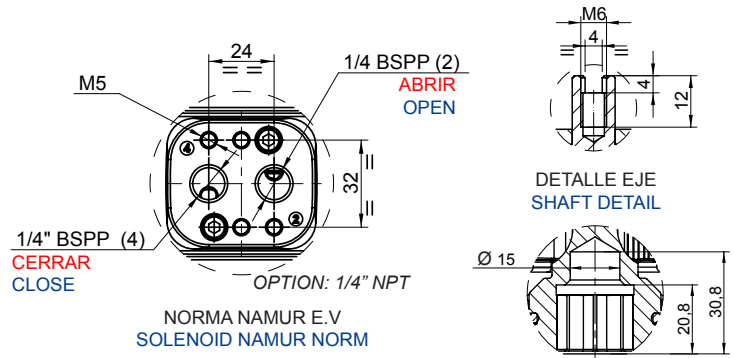

PARES SIMPLE EFECTO SPRING RETURN TORQUES

PAG10S	PAR MUELLES SPRING TORQUES		PAR A LA PRESIÓN INDICADA AIR TORQUE AT INDICATED PRESSURE														
			3		4		5		5,5		6		7		8		bar
			43,5		58		72,5		79,8		87		101,5		116		p.s.i
N	INICIAL INITIAL	FINAL END	INICIAL INITIAL	FINAL END	INICIAL INITIAL	FINAL END	INICIAL INITIAL	FINAL END	INICIAL INITIAL	FINAL END	INICIAL INITIAL	FINAL END	INICIAL INITIAL	FINAL END	INICIAL INITIAL	FINAL END	
6*	22,8	15,4					13,8	6,4	17,1	9,7	20,1	12,7	26,5	19,1	32,8	25,4	Nm
	201,8	136,3					121,7	56,2	151,3	85,9	177,9	112,4	234,1	168,6	290,3	224,8	Lb.in
5	19	12,9					16,3	10,2	19,7	13,5	22,7	16,5	29	22,9	35,4	29,2	Nm
	168,2	113,7					144,3	89,8	173,9	119	200,5	146	256,7	202,2	312,9	258,4	Lb.in
4	15,2	10,3			12,6	7,6	18,9	14	22,3	17,3	25,3	20,3	31,6	26,7	38	33	Nm
	134,5	90,7			111,1	67,3	167,3	123,5	196,9	153,1	223	179,7	279,7	235,9	335,9	292,1	Lb.in
3	11,4	7,7	8,8	5,1	15,1	11,4	21,5	17,8	24,8	21,1	27,8	24,1	34,2	30,5			Nm
	100,9	68,2	77,4	44,7	133,6	100,9	189,8	157,1	219	186,8	246,1	213,3	302,3	269,5			Lb.in
2	7,6	5,2	11,3	8,9	17,7	15,2	24	21,6	27,4	24,9	30,4	27,9					Nm
	67,3	45,6	100	78,3	156,2	134,5	212,4	190,7	242,1	220,4	268,6	246,9					Lb.in

N: Número de muelles por banda
Number of springs per side

* Número de muelles estándar
* Standard number of springs