

DESPIECE

DISASSEMBLY



ACTUADOR NEUMÁTICO DE ALUMINIO
(GIRO: 180°)
ALUMINIUM PNEUMATIC ACTUATOR
(ROTATION: 180°)



PAGW: Doble Efecto / Double Acting

PAGWS: Simple Efecto / Spring Return

Nº	Descripción Description	Cant. Quant.	Material Material
1	TORNILLO ALLEN TAPA CAP ALLEN SCREW	8	ACERO INOXIDABLE AISI-304 AISI-304 STAINLESS STEEL
2	TAPA CAP	2	ALEACIÓN ALUMINIO (2) + (7) ALUMINIUM ALLOY (2) + (7)
3	JUNTA TÓRICA TAPA CAP-O-RING	2	N.B.R. N.B.R.
4	ÉMBOLO PISTON	2	ALEACIÓN ALUMINIO (2) ALUMINIUM ALLOY (2)
5	CILINDRO CYLINDER	1	ALEACIÓN DE ALUMINIO (2) + (1) ALUMINIUM ALLOY (2) + (1)
6	ARANDELA WASHER	1	POLIACETAL POLYACETAL
7	ANILLO DE SEGURIDAD SPRING CLIP	1	ACERO INOXIDABLE STAINLESS STEEL
8	INDICADOR VISUAL POSITION INDICATOR	1	POLIACETAL POLYACETAL
9	GUIA ÉMBOLO PISTON GUIDE	2	NYLON NYLON
10	ANILLO GUIA GUIDE RING	2	POLIACETAL + Mb POLYACETAL + Mb
11	JUNTA TÓRICA ÉMBOLO PISTON O-RING	2	N.B.R. N.B.R.
12	JUNTA TÓRICA EJE SHAFT O-RING	2	N.B.R. N.B.R.
13	JUNTA TÓRICA EJE SHAFT O-RING	2	N.B.R. N.B.R.
14	JUEGO DE MUELLES SPRINGS SET	2	DIN-17223-C (2) (4) DIN-17223-C (2) (4)
15	PLACA BASE (ISO-5211) BASE PLATE (ISO-5211)	1	POLIAMIDA + FV POLYAMIDE + FG
16	EJE SHAFT	1	POLIAMIDA + INSERTO INOX. POLYAMIDE + S.S. INSERT
17	DADO DE CONEXIÓN DRIVE ADAPTER	1	ACERO INOXIDABLE AISI-316 AISI-316 STAINLESS STEEL
18	ARANDELA TAPA CAP WASHER	8	ACERO INOXIDABLE AISI-304 AISI-304 STAINLESS STEEL
19	TORNILLO ALLEN ALLEN SCREW	2	ACERO INOXIDABLE AISI-304 AISI-304 STAINLESS STEEL
20	TUERCA NUT	4	ACERO INOXIDABLE AISI-304 AISI-304 STAINLESS STEEL
21	TUERCA NUT	4	ACERO INOXIDABLE AISI-304 AISI-304 STAINLESS STEEL
22	PLACA CONEXIÓN NEUMÁTICA PNEUMATIC CONNECTION PLATE	1	POLIAMIDA + FV POLYAMIDE + FG
23	TORNILLO ALLEN PLACA PLATE ALLEN SCREW	2	ACERO INOXIDABLE AISI-304 AISI-304 STAINLESS STEEL
24	JUNTA TÓRICA PLACA PLATE O-RING	2	N.B.R. N.B.R.

- (1) RECUBRIMIENTO CON POLIAMIDA.
COVERED WITH POLYAMIDE.
- (2) RECUBRIMIENTO POR CATAFORESIS.
COVERED BY CATAPHORESIS.
- (4) CANTIDAD VARIABLE, CONSULTAR TABLAS PARES SIMPLE EFECTO.
VARIABLE QUANTITY, PLEASE SEE THE SPRING RETURN TORQUE CHART.
- (7) RECUBR. CON POLIURETANO.
COVERED WITH POLYURETHANE.

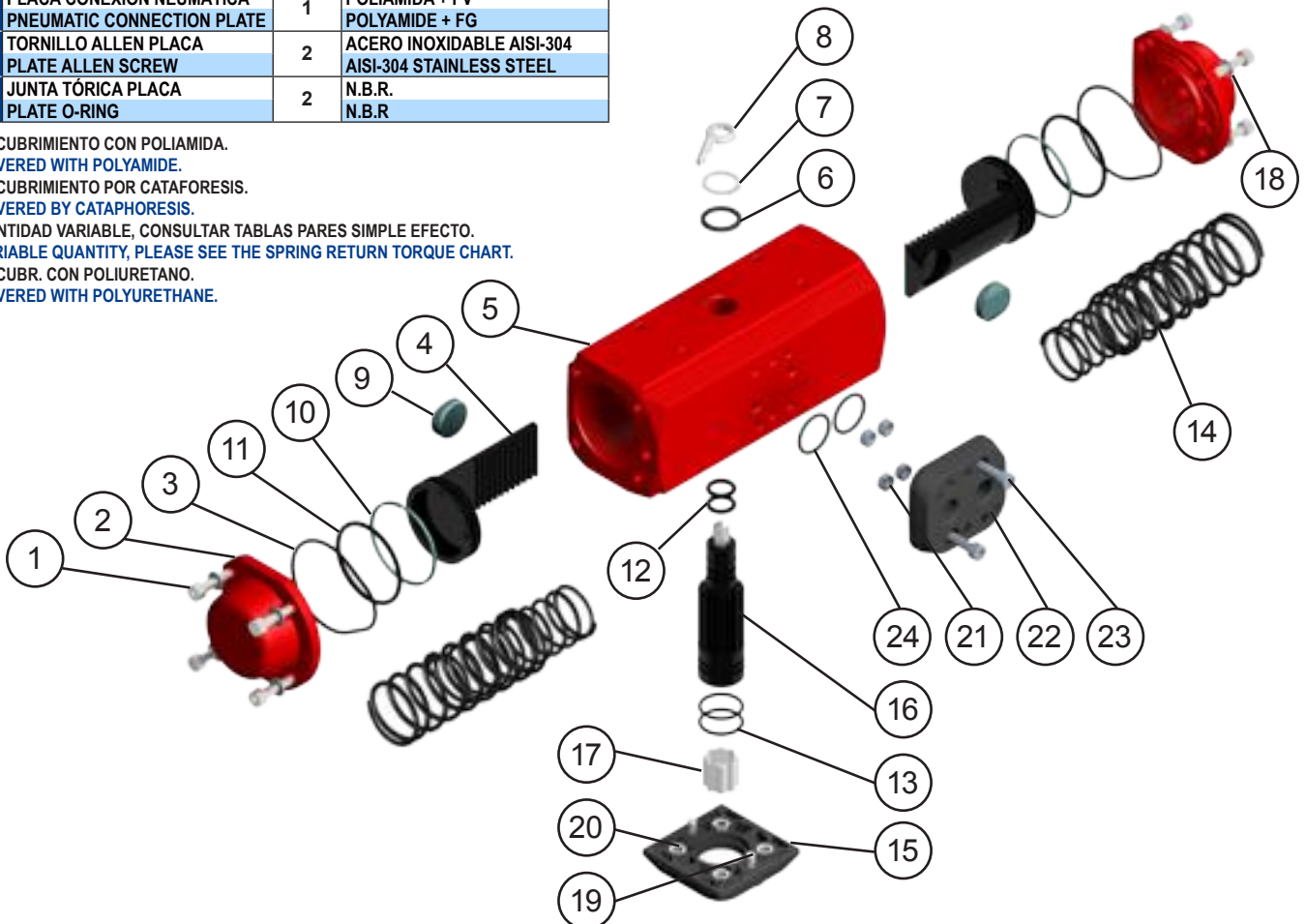

MODELOS MODELS	TIEMPO DE MANIOBRA EN SEG. CYCLE TIME IN SECS.		PESOS WEIGHTS		CAPACIDAD EN LITROS CAPACITY IN LITRES	
	PARA ABRIR TO OPEN	PARA CERRAR TO CLOSE	Kg.	Lb.	PARA ABRIR TO OPEN	PARA CERRAR TO CLOSE
PAGW	0,13	0,13	1,3	2,76	0,123	0,158
PAGWS	0,20	0,20	1,5	3,31	0,123	

Tiempo de maniobra sin par resistente a 6 bar.
Cycle time w/o resistant torque at 6 bar.

Dimensiones en mm.
Dimensions in mm.

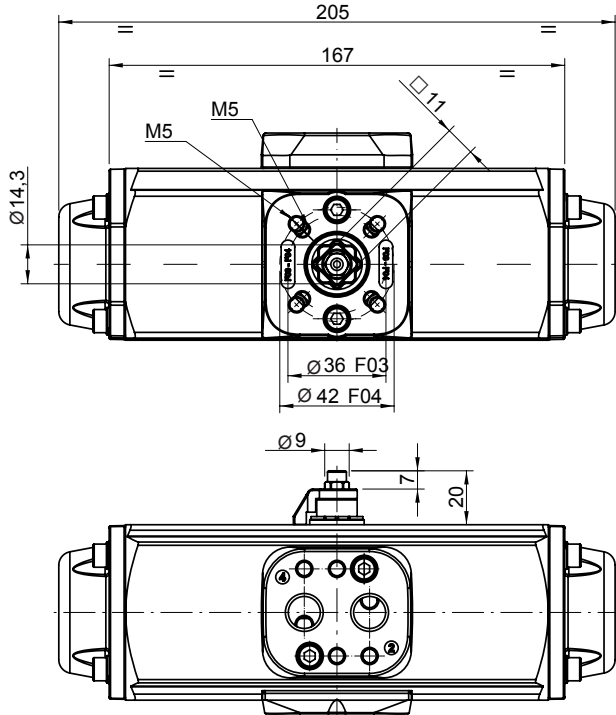

Para calcular el consumo, multiplicar las cifras del cuadro por la presión real de trabajo.

To calculate the consumption, multiply the above figures by the real working pressure.

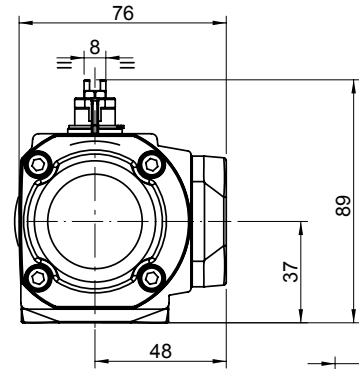
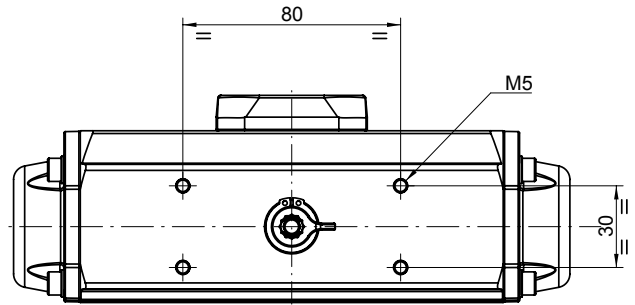

PARES DOBLE EFECTO DOUBLE ACTING TORQUES

PAGW	PRESION AIRE AIR PRESSURE						
bar	3	4	5	5,5	6	7	8
p.s.i	43,5	58	72,5	79,8	87	101,5	116
Nm	7,9	11,3	14,1	15,5	17	19,8	22,9
Lb.in	69,9	100	124,8	137,2	150,5	175,2	202,7

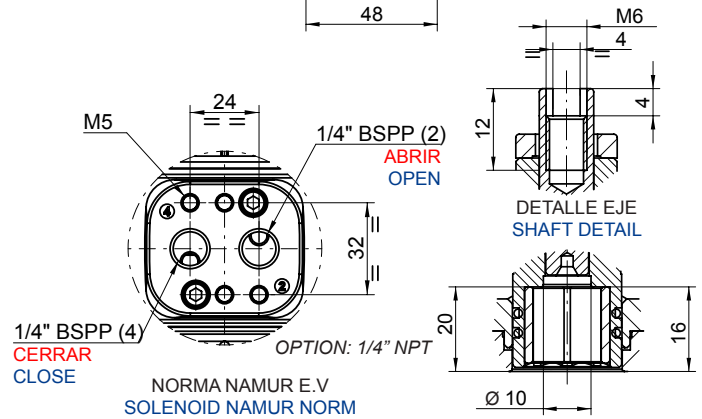

PARES SIMPLE EFECTO SPRING RETURN TORQUES

PAGWS	PAR MUELLES SPRING TORQUES	PAR A LA PRESIÓN INDICADA AIR TORQUE AT INDICATED PRESSURE															
		3		4		5		5,5		6		7		8		bar	
		43,5		58		72,5		79,8		87		101,5		116		p.s.i	
N	INICIAL INITIAL	FINAL END	INICIAL INITIAL	FINAL END	INICIAL INITIAL	FINAL END	INICIAL INITIAL	FINAL END	INICIAL INITIAL	FINAL END	INICIAL INITIAL	FINAL END	INICIAL INITIAL	FINAL END	INICIAL INITIAL	FINAL END	
4*	9,7	6,1					8	4,4	9,4	5,8	10,9	7,3	13,7	10,1	16,8	13,2	Nm
	86,1	53,8					71	38,7	83,4	51,1	96,6	64,3	121,4	89,1	148,9	116,6	Lb.in
3	8,8	5,5			5,8	2,5	8,6	5,3	10	6,7	11,5	8,2	14,3	11	17,4	14,1	Nm
	78,1	48,4			51,6	21,9	76,4	46,7	88,8	59,1	102	72,4	126,8	97,2	154,3	124,6	Lb.in
2	6,7	4,3	3,6	1,2	7	4,6	9,8	7,4	11,2	8,8	12,7	10,3	15,5	13,1			Nm
	59	37,7	32,2	10,7	62,3	40,8	87,1	65,6	99,5	78	112,8	91,3	137,5	116			Lb.in
1	4,3	2,4	5,5	3,6	8,9	7	11,7	9,8	13,1	11,2	14,6	12,7					Nm
	37,7	21,5	48,4	32,2	78,5	62,3	103,3	87,1	115,7	99,5	129	112,8					Lb.in

N: Número de muelles por banda
Number of springs per side

* Número de muelles estándar
* Standard number of springs