

DESPIECE

DISASSEMBLY



ACTUADOR NEUMÁTICO DE POLIAMIDA
POLYAMIDE PNEUMATIC ACTUATOR



PP10: Doble Efecto / Double Acting

PP10S: Simple Efecto / Spring Return

Nº	Descripción Description	Cant. Quant.	Material Material
1	TORNILLO AVELLANADO TAPA CAP COUNTERSUNK SCREW	8	ACERO INOX. AISI-304 AISI-304 STAINLESS STEEL
2	TAPA CAP	2	POLIAMIDA + FV POLYAMIDE + FG
3	JUNTA TÓRICA TAPA CAP O-RING	2	N.B.R. N.B.R.
4	ÉMBOLO PISTON	2	POLIARILAMIDA POLYARILAMIDE
5	CILINDRO CYLINDER	1	POLIAMIDA + FV POLYAMIDE + FG
6	ARANDELA WASHER	1	POLIACETAL POLYACETAL
7	ANILLO DE SEGURIDAD SPRING CLIP	1	ACERO INOXIDABLE STAINLESS STEEL
8	INDICADOR VISUAL POSITION INDICATOR	1	POLIAMIDA POLYAMIDE
9	GUIA ÉMBOLO PISTON GUIDE	2	POLIACETAL POLYACETAL
10	ANILLO GUIA GUIDE RING	2	POLIACETAL POLYACETAL
11	JUNTA TÓRICA ÉMBOLO PISTON O-RING	2	N.B.R. N.B.R.
12	JUNTA TÓRICA O-RING	2	N.B.R. N.B.R.
13	JUNTA TÓRICA O-RING	2	N.B.R. N.B.R.
14	MUELLES PRECARGADOS PRELOADED SPRINGS	12	DIN-17223-C (6) (4) DIN-17223-C (6) (4)
15	PROTECTOR / TUERCA PROTECTOR / NUT	8	POLIAMIDA / INOX AISI-304 POLYAMIDE / S.S AISI-304
16	EJE SHAFT	1	ACERO INOX. AISI-303 AISI-303 STAINLESS STEEL
17	PIÑÓN GEAR	1	ALEACIÓN DE ALUMINIO (5) ALUMINIUM ALLOY (5)
18	INSERTOS ROSCADOS THREAD INSERTS	10	ACERO INOXIDABLE STAINLESS STEEL

- (4) CANTIDAD VARIABLE, CONSULTAR TABLAS PARES SIMPLE EFECTO.
VARIABLE QUANTITY, PLEASE SEE THE SPRING RETURN TORQUE CHART.
- (5) BRUÑIDO CON BOLAS.
BALL BURNISHING.
- (6) PASIVADO DE CROMO TRIVALENTE.
TRIVALENT CHROMINIUM PASSIVATION.

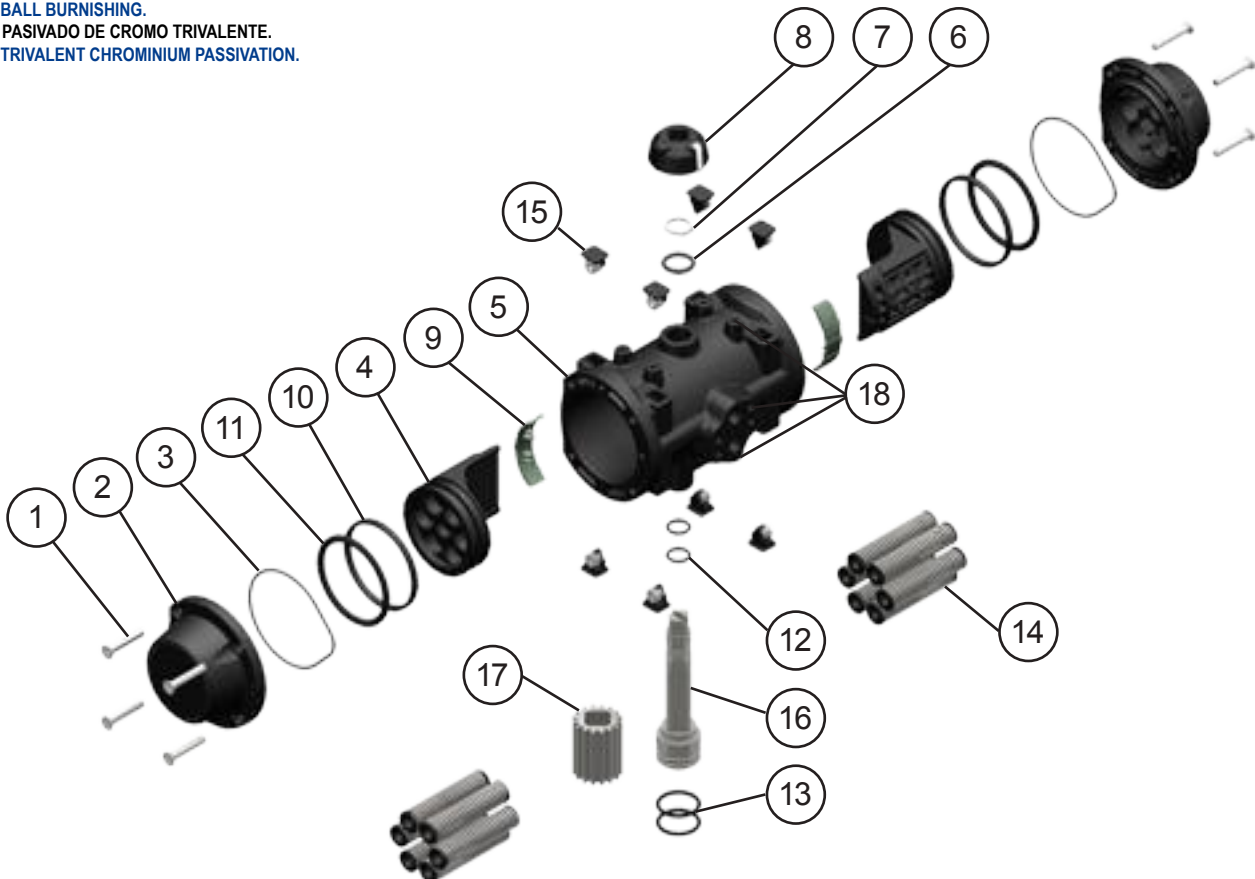

MODELOS MODELS	TIEMPO DE MANIOBRA EN SEG. CYCLE TIME IN SECS.		PESOS WEIGHTS		CAPACIDAD EN LITROS CAPACITY IN LITRES	
	PARA ABRIR TO OPEN	PARA CERRAR TO CLOSE	Kg.	Lb.	PARA ABRIR TO OPEN	PARA CERRAR TO CLOSE
PP10	0,25	0,25	1,65	3,64	0,35	0,45
PP10S	0,3	0,3	2,03	4,48	0,35	

Tiempo de maniobra sin par resistente a 6 bar.
Cycle time w/o resistant torque at 6 bar.

Dimensiones en mm.
Dimensions in mm.

Para calcular el consumo, multiplicar las cifras del cuadro por la presión real de trabajo.

To calculate the consumption, multiply the above figures by the real working pressure.

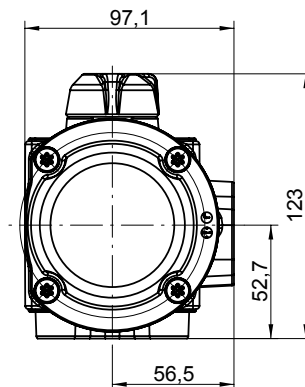
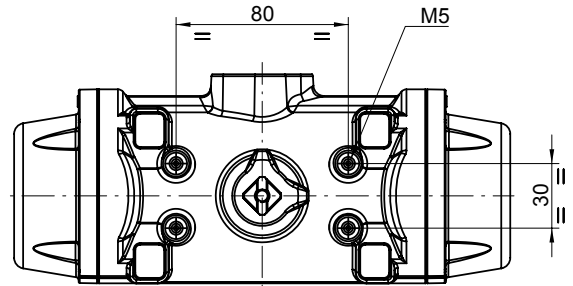
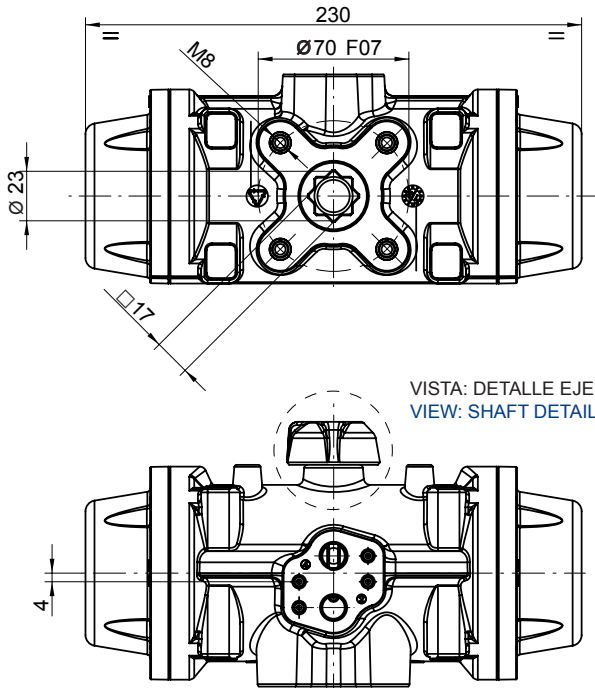

PARES DOBLE EFECTO DOUBLE ACTING TORQUES

PP10	PRESION AIRE AIR PRESSURE						
bar	3	4	5	5,5	6	7	8
p.s.i	43,5	58	72,5	79,8	87	101,5	116
Nm	32,9	45,6	58,3	65	71	83,7	96,4
Lb.in	291	404	516	575	628	741	853

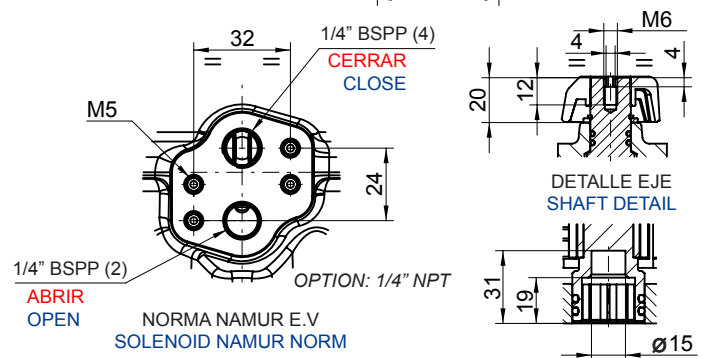

PARES SIMPLE EFECTO SPRING RETURN TORQUES

PP10S	PAR MUELLES SPRING TORQUES		PAR A LA PRESIÓN INDICADA AIR TORQUE AT INDICATED PRESSURE																
			3		4		5		5,5		6		7		8		bar		
N	INICIAL INITIAL	FINAL END	43,5		58		72,5		79,8		87		101,5		116		p.s.i		
6*	45,6	30,8							27,5	12,7	34,2	19,4	40,2	25,4	52,9	38,1	65,6	50,8	Nm
	403,6	272,6							243,4	112,4	302,7	171,7	355,8	224,8	468,2	337,2	580,6	449,6	Lb.in
5	38	25,7			19,9	7,6	32,6	20,3	39,3	27	45,3	33	58	45,7	70,7	58,4			Nm
	336,3	227,5			176,1	67,3	288,5	179,7	347,8	239	400,9	292,1	513,3	404,5	625,7	516,9			Lb.in
4	30,4	20,5	12,4	2,5	25,1	15,2	37,8	27,9	44,5	34,6	50,5	40,6	63,2	53,3	75,9	66			Nm
	269,1	181,4	109,7	22,1	222,2	134,5	334,6	246,9	393,9	306,2	447	359,3	559,4	471,7	671,8	584,1			Lb.in
3	22,8	15,4	17,5	10,1	30,2	22,8	42,9	35,5	49,6	42,2	55,6	48,2	68,3	60,9					Nm
	201,8	136,3	154,9	89,4	267,3	201,8	379,7	314,2	439	373,5	492,1	426,6	604,5	539,0					Lb.in
2	15,2	10,3	22,6	17,7	35,3	30,4	48	43,1	54,7	49,8	60,7	55,8							Nm
	134,5	91,2	200	156,7	312,4	269,1	424,8	381,5	484,1	440,8	537,2	493,9							Lb.in

N: Número de muelles por banda
Number of springs per side

* Número de muelles estándar
* Standard number of springs