

DESPIECE

DISASSEMBLY



ACTUADOR NEUMÁTICO DE POLIAMIDA
POLYAMIDE PNEUMATIC ACTUATOR

2014



PP20: Doble Efecto / Double Acting

PP20S: Simple Efecto / Spring Return

Nº	Descripción Description	Cant. Quant.	Material Material
1	TORNILLO AVELLANADO TAPA CAP COUNTERSUNK SCREW	8	ACERO INOX. AISI-304 AISI-304 STAINLESS STEEL
2	TAPA CAP	2	POLIAMIDA + FV POLYAMIDE + FG
3	JUNTA TÓRICA TAPA CAP O-RING	2	N.B.R N.B.R
4	ÉMBOLO PISTON	2	POLIARILAMIDA POLYARILAMIDE
5	CILINDRO CYLINDER	1	POLIAMIDA + FV POLYAMIDE + FG
6	ARANDELA WASHER	1	POLIACETAL POLYACETAL
7	ANILLO DE SEGURIDAD SPRING CLIP	1	ACERO INOXIDABLE STAINLESS STEEL
8	INDICADOR VISUAL POSITION INDICATOR	1	POLIAMIDA POLYAMIDE
9	GUIA ÉMBOLO PISTON GUIDE	2	POLIACETAL POLYACETAL
10	ANILLO GUIA GUIDE RING	2	POLIACETAL POLYACETAL
11	JUNTA TÓRICA ÉMBOLO PISTON O-RING	2	N.B.R. N.B.R.
12	JUNTA TÓRICA O-RING	2	N.B.R. N.B.R.
13	JUNTA TÓRICA O-RING	2	N.B.R. N.B.R.
14	MUELLES PRECARGADOS PRELOADED SPRINGS	12	DIN-17223-C (6) (4) DIN-17223-C (6) (4)
15	PROTECTOR / TUERCA PROTECTOR / NUT	8	POLIAMIDA / INOX AISI-304 POLYAMIDE / S.S AISI-304
16	EJE SHAFT	1	ACERO INOX. AISI-303 AISI-303 STAINLESS STEEL
17	PIÑÓN GEAR	1	ALEACIÓN DE ALUMINIO (5) ALUMINIUM ALLOY (5)
18	INSERTOS ROSCADOS THREAD INSERTS	10	ACERO INOXIDABLE STAINLESS STEEL

- (4) CANTIDAD VARIABLE, CONSULTAR TABLAS PARES SIMPLE EFECTO.
VARIABLE QUANTITY, PLEASE SEE THE SPRING RETURN TORQUE CHART.
- (5) BRUÑIDO CON BOLAS.
BALL BURNISHING.
- (6) PASIVADO DE CROMO TRIVALENTE.
TRIVALENT CHROMINIUM PASSIVATION.

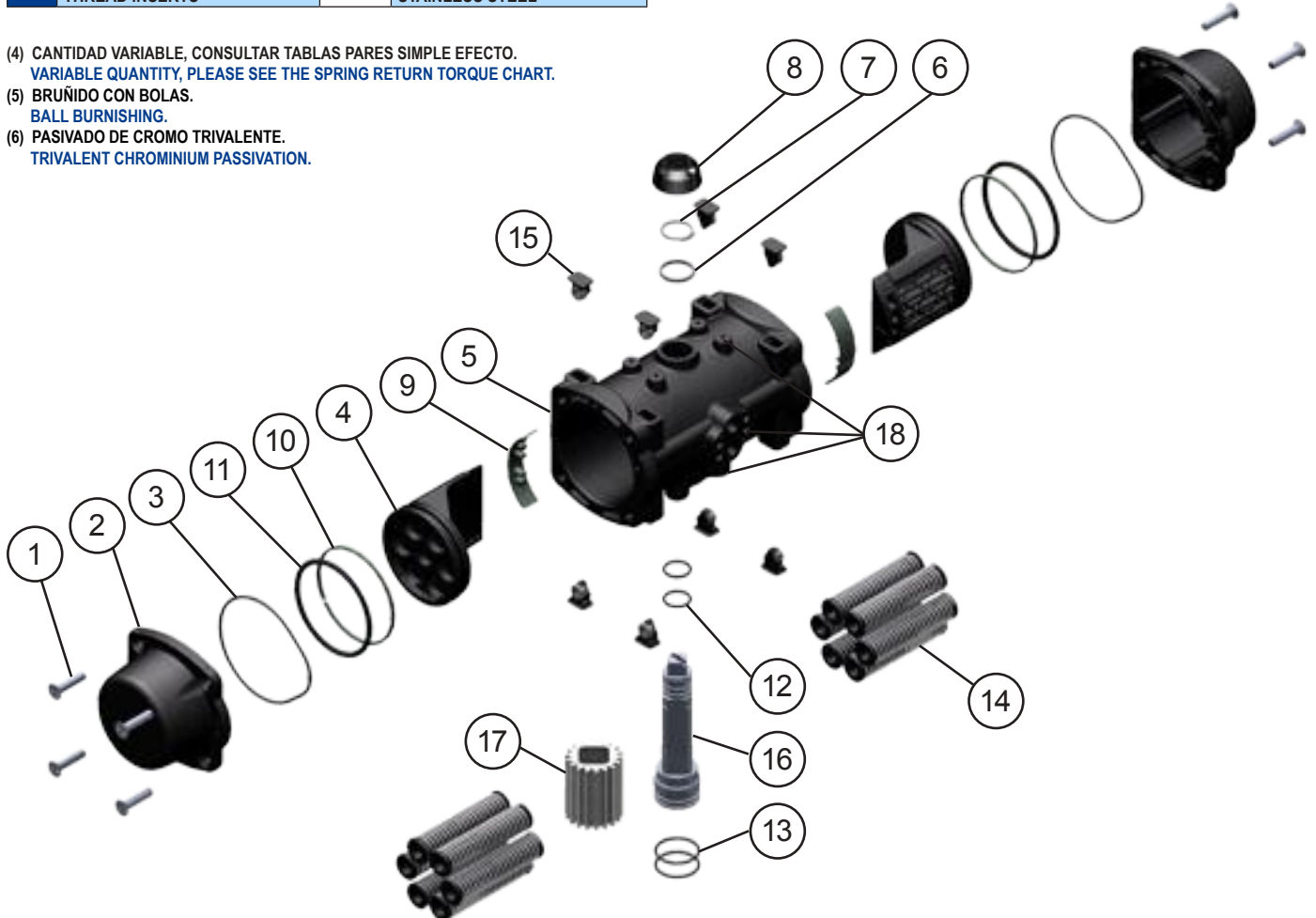

MODELOS MODELS	TIEMPO DE MANIOBRA EN SEG. CYCLE TIME IN SECS.		PESOS WEIGHTS		CAPACIDAD EN LITROS CAPACITY IN LITRES	
	PARA ABRIR TO OPEN	PARA CERRAR TO CLOSE	Kg.	Lb.	PARA ABRIR TO OPEN	PARA CERRAR TO CLOSE
PP20	0,4	0,4	3,22	7,1	0,8	1,15
PP20S	0,5	0,5	4,22	9,3	0,8	-

Tiempo de maniobra sin par resistente a 6 bar.
Cycle time w/o resistant torque at 6 bar.

Dimensiones en mm.
Dimensions in mm.

Para calcular el consumo, multiplicar las cifras del cuadro por la presión real de trabajo.

To calculate the consumption, multiply the above figures by the real working pressure.

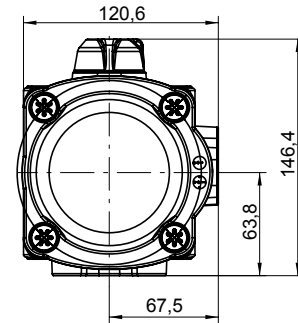
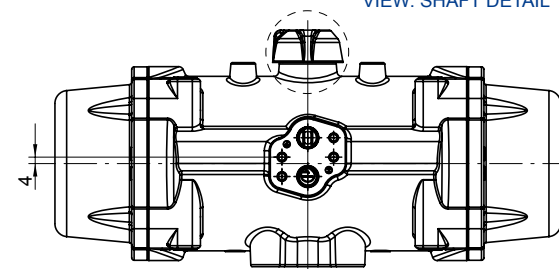
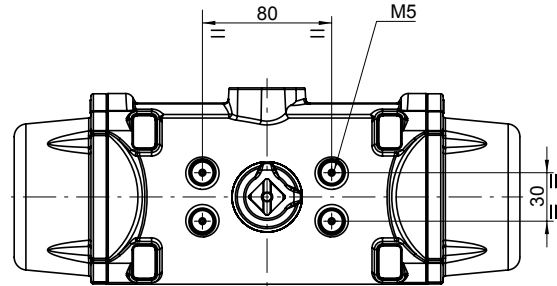
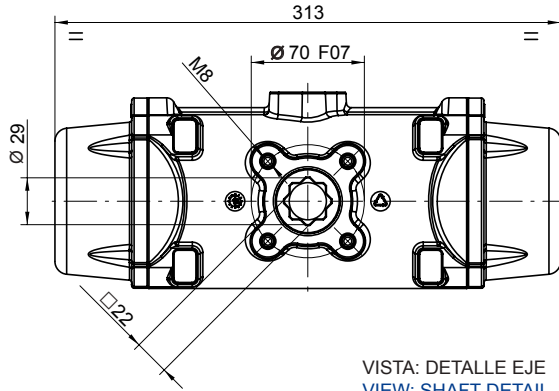

PARES DOBLE EFECTO DOUBLE ACTING TORQUES

PP20	PRESION AIRE AIR PRESSURE						
bar	3	4	5	5,5	6	7	8
p.s.i	43,5	58	72,5	79,8	87	101,5	116
Nm	77,7	107	136,3	150,9	165,4	194,8	224
Lb.in	687,8	947,3	1.206	1.335	1.465	1.724	1.983

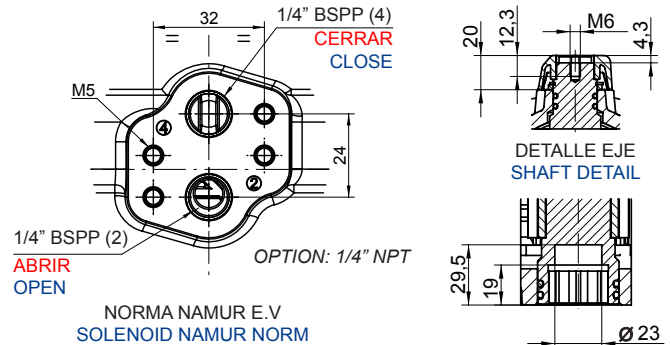

PARES SIMPLE EFECTO SPRING RETURN TORQUES

PP20S	PAR MUELLES SPRING TORQUES		PAR A LA PRESIÓN INDICADA AIR TORQUE AT INDICATED PRESSURE																
			3		4		5		5,5		6		7		8		bar		
N	INICIAL INITIAL	FINAL END	43,5		58		72,5		79,8		87		101,5		116		p.s.i		
6*	104,7	65,8							70,5	31,6	85,2	46,3	99,7	60,8	129	90,1	158,2	119,3	Nm
	926,7	582,4							624	279,7	754,1	409,8	882,4	538,1	1.142	797	1.400	1.056	Lb.in
5	87,2	54,8			52,2	19,8	81,5	49,1	96,2	63,8	110,7	78,3	140	107,6	169,2	136,8			Nm
	771,8	485			462	175	721,3	434,6	851,4	564,7	980	693	1.239	952,3	1.497	1.211			Lb.in
4	69,8	43,9	33,8	8	63,1	37,2	92,4	66,5	107,1	81,2	121,6	95,7	150,9	125	180,1	154,2			Nm
	617,8	388,5	299,2	69,9	558,5	329,2	817,8	588,6	947,9	718,7	1.076	847	1.336	1.106	1.594	1.365			Lb.in
3	52,3	32,9	44,8	25,4	74,1	54,7	103,4	84	118,1	98,7	132,6	113,2	161,9	142,5					Nm
	462,9	291,2	396,5	224,8	655,8	484,1	915,2	743,5	1045	873,6	1.174	1.002	1.433	1.261					Lb.in
2	34,9	21,9	55,8	42,8	85,1	72,1	114,4	101,4	129,1	116,1	143,6	130,6							Nm
	308,9	193,8	493,9	378,8	753,2	638,1	1.012	897,5	1.143	1.027	1.271	1.156							Lb.in

N: Número de muelles por banda
Number of springs per side

* Número de muelles estándar
* Standard number of springs